

TILEVISION® 23

Back Box Installation Instructions

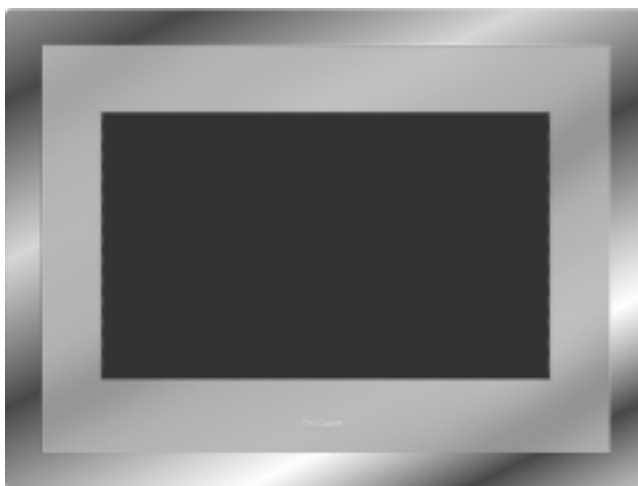



TileVision® is Designed and Manufactured by:



PORTER LANCASTRIAN LIMITED

www.tilevision.tv

23" Widescreen TileVision®

	CAUTION RISK OF ELECTRIC SHOCK DO NOT OPEN	
<p>WARNING: TO PREVENT INJURY, THIS APPARATUS MUST BE SECURELY ATTACHED TO THE WALL IN ACCORDANCE WITH THE INSTALLATION INSTRUCTIONS.</p> <p>CAUTION: DO NOT REMOVE COVER. NO USER-SERVICEABLE PARTS INSIDE. REFER SERVICING TO QUALIFIED SERVICE PERSONNEL. BEWARE OF STATIC SENSITIVE PARTS.</p>		



This symbol is intended to alert the user to the presence of important operating and maintenance (servicing) instructions in the literature accompanying the appliance.

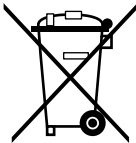

Waste Electrical and Electronic Equipment (WEEE) Directive

In the European Union, this symbol indicates that this product should not be disposed of with household waste. It should be deposited at an appropriate facility to enable recovery and recycling.

The back box assembly package consists of:

- 2 waterproof speakers
- 2 lengths speaker cable
- 1 24V DC Adaptor with 4 metre cord
- 1 AC Power cord – 100–240V
- 1 stainless steel back box
- 1 aperture protective cover
- 1 back box installation instructions

If any items are missing, contact your dealer.

Safety Instructions

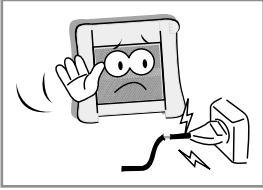

Do not use a damaged socket and do not let the power cord touch a heat source.

– This may cause an electric shock or fire.

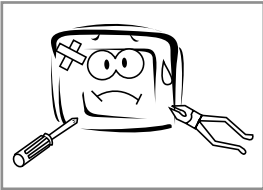

Do not attempt to service the unit.

Contact an authorised dealer or repair service.

– Servicing the unit yourself may cause an electric shock or fire.

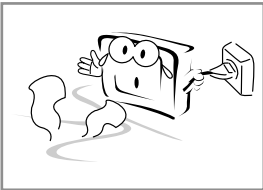

If there are any unusual sounds or smells coming from the unit, unplug it immediately and contact an authorised dealer or repair service.

– This may cause an electric shock or fire.



If an outside antenna is connected to the unit, ensure the external to internal cable entry is fully sealed

– This may cause an electric shock or fire.

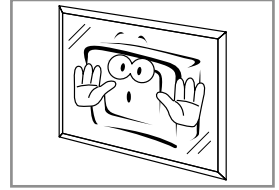

Do not add an additional screen or cover the TileVision's glass.

– The heated screen prevents condensation forming in steamy rooms and covering the screen may cause the unit to overheat.

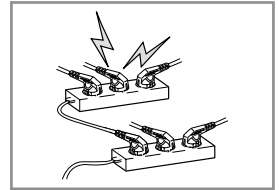

Do not connect too many extension cords or plugs to an outlet.

– This may cause a fire.

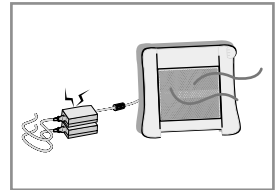

Keep the power adaptor away from any heat source.

– This may cause a fire.

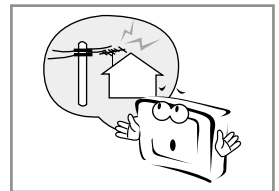

Ensure the antenna is located away from overhead cables.

– This may cause an electric shock.

FAILURE TO OBSERVE THE ABOVE SAFETY WARNINGS MAY INVALIDATE THE WARRANTY

Unpacking and Initial Assembly

Please note – **A technically competent person should carry out the installation of your TileVision® unit.**

Unpacking your TileVision® unit and assembling the back box

Within the back box there are two right-angled brackets – remove the retaining screws and take them out.

The three positioning holes on the brackets allow the front edge of the back box to be fitted flush with the front face of the surrounding tiles. The three positions give a variation of 11mm, 15mm and 20mm from the front face of the back box and will allow sufficiently precise alignment.

Once the best position has been established, screw the brackets to the sides of the back box using the retaining screws, as shown below.

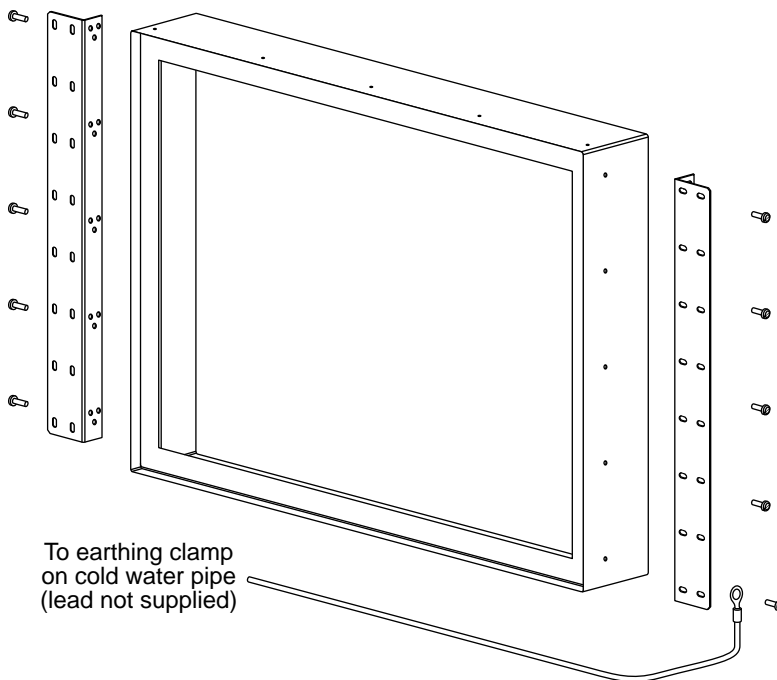

Note: Your qualified electrical installer must use one of the retaining screws as an earth point to earth the unit to ground.

Installing the Back Box

Installation and positioning

If this has not already been cut, the 23" unit requires a recess of 635 mm x 455 mm and 90 mm depth from the front face of the tiles.

When positioning the brackets you must ensure that there is sufficient depth to suit your tile and adhesive thickness so as to set the front edge of the back box level or just recessed from the surface of the tiled surface.

Fit the back box ensuring that the cable inlets are facing downwards and that the recess in the wall is chased out to accept the cabling. It is essential that all cables are fed into the bottom of the unit to prevent the incursion of moisture.

With the angle brackets correctly positioned, secure the back box to the wall.

Example of a back box installed in a 'solid' wall

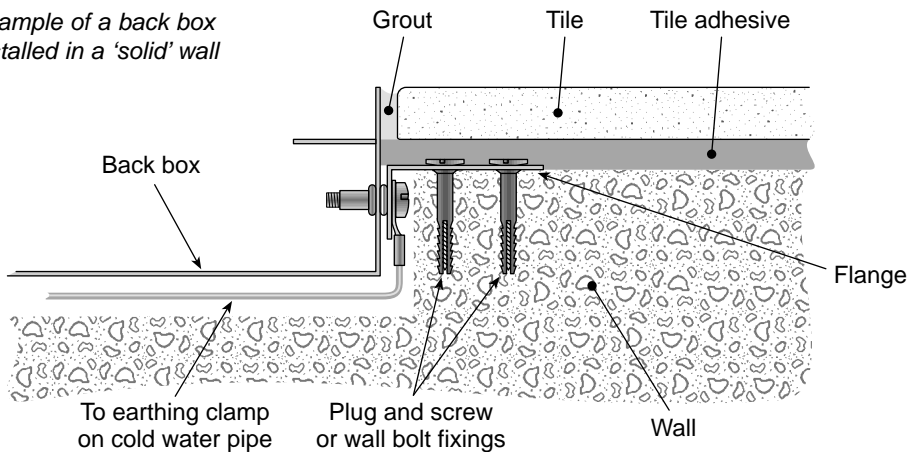

Note: Removal of the front glass requires a force of 100 lbs using a glass sucker, therefore, the box must be secured to the wall in such a manner to easily withstand such a pulling force.

For further instructions please see inside the rear of the back box itself.

All cables must be routed into the back box with 500 mm of cable protruding before installing as shown above.

If connections for PC Digital (DVI-I), Headphones, PC Analog (D-SUB), SCART1 (Full), SCART2 (Half), Audio, and S-Video are to be used, then the wall chasing must allow sufficient room for the cables.

Cabling

Please note – **All electrical installation should be carried out by a fully qualified electrician and all fire & safety regulations should be obeyed.**

Power Requirement (Mains)

TileVision® requires a 13 amp socket outlet connected to a 240V mains supply via a readily accessible isolation switch mounted in close proximity to the unit. This electrical installation shall include an all-pole switch with a contact separation of at least 3 mm in each pole, both the socket and pull switch must conform to the latest safety specification and be protected via an RCCD device or similar. This socket must be fitted in a dry area, away from any moisture (usually in ceiling). **The mains plug should be fitted with a 5 amp fuse.**

TileVision® Power Supply (24 V)

Plug the power supply lead into the mains socket and plug the 24V transformer/power supply onto the end of this mains lead.

The power supply is not waterproof and so must be positioned in a dry, well-ventilated area away from any water or moisture. It is fitted with an integral 4 metre lead to feed the TileVision® unit, this must not be cut, shortened, lengthened, etc. as this could potentially damage the unit and also has implications regarding the unit's safety.

Feed the cable from the power supply through a cable inlet into the TileVision® unit – making sure that there is approximately 500 mm of slack at this end. Any spare cable should be neatly coiled in a safe place, away from any water or heat generated from lights, etc.

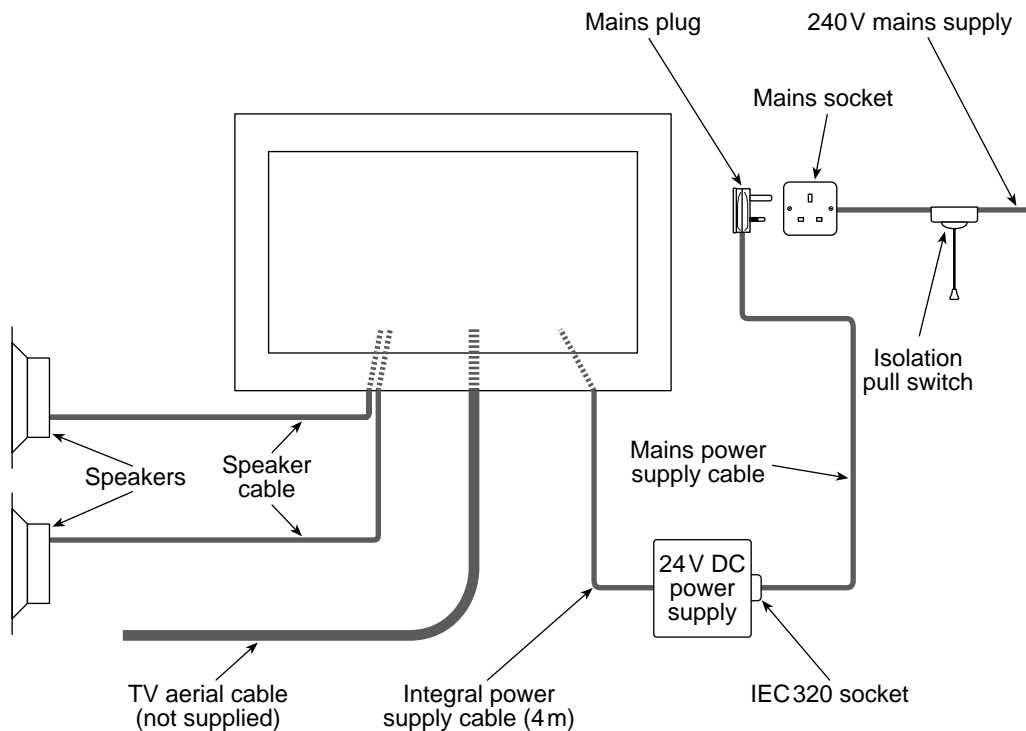

Installing the speakers supplied

For each speaker you should cut a 123mm diameter hole and four 4.5mm holes in the ceiling using the template supplied. Make sure not to cut through any ceiling joists, cables, pipes, etc. This hole should be no more than a 3 metre cable run from the TileVision® unit.

A 3 metre length of 2-core speaker cable is provided with the TileVision® unit and this should be run from the TileVision® back box to the position of the speaker.

Feed one end of the speaker cable through the second cable inlet, leaving approximately 500mm of slack in the back box. All slack cable should be pulled back and left in the ceiling area.

Connect the other end of the speaker cable to the ceiling speaker by pushing the spade connector onto the appropriate connector. Ensure the striped conductor is connected to the negative terminal and the plain conductor to the positive terminal.

Fix the speakers to the ceiling using the screws and fittings supplied.

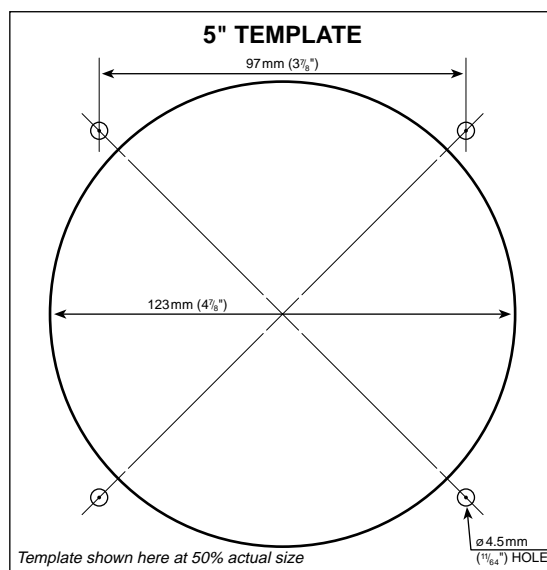

TV Aerial Feed

Take a 75Ω feed (CT100 or similar quality cable) from your present television aerial or distribution system and feed this into the TileVision® back box through the third cable inlet. Terminate with a standard COAX termination. Ensure that the cable is not kinked.

Back box aperture protective cover

The back box is now correctly installed, please push the aperture cover provided into the front of the back box (printed side outward) to protect the sealing flanges from damage whilst awaiting the installation of the front assembly.

Note: The signal level fed to the set must be at least 60dB/1millivolt or the picture may be noisy. A TV Distribution Amplifier may be required if you are in an area of weak signal or if other televisions are already being fed from the aerial. If in doubt, consult a qualified aerial technician.

Refer to page 6 of the TileVision® Instruction Manual for further information on speaker phasing and additional input and output connections.



PORTER LANCASTRIAN LIMITED
www.tilevision.tv